

MARTATCH
ATTACHMENTS

SNOWBLADES

**Hydraulic Angle
Heavy Duty Snowblade**

OPERATOR'S MANUAL

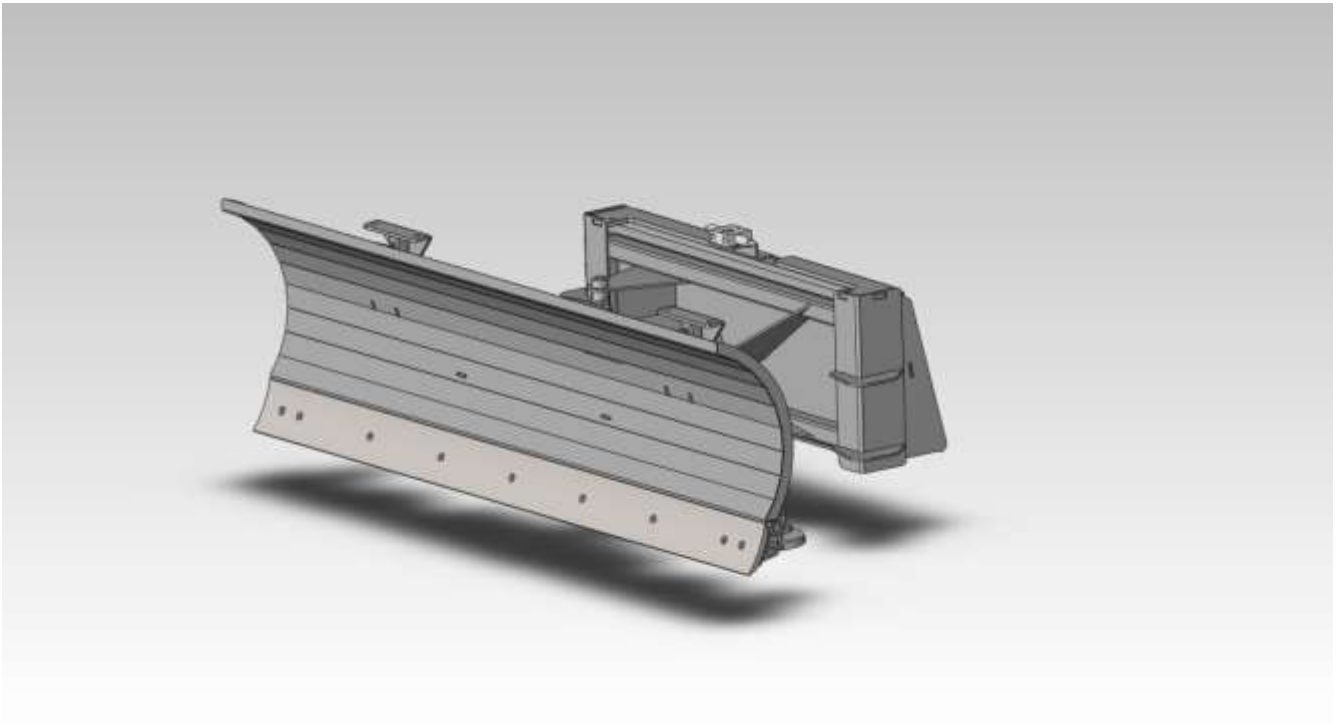

HYDRAULIC ANGLE SNOW BLADES

TABLE OF CONTENTS

Introduction, General Information4

Owner and Operator Safety Information5

Specifications8

Mounting and Setup12

Operation13

Maintenance

 Grease Points.....14

Parts Illustrations

 Snow Blade15

Trouble Shooting16

Warranty Policy.....17

MARTATCH ATTACHMENTS

4350 HESSEN STRASSE
R.R. #3
WELLESLEY, ON N0B 2T0
Canada
Phone: 1-800-698-5510
Email: sales@martatch.com
Website: www.martatch.com

INTRODUCTION

Congratulations on your purchase of a new Martatch Attachments Snow Blade. You or any other person, who will be assembling, operating, maintaining, or working with this product are required to read and completely understand the information and instructions contained in this manual. Contact Martatch Attachments with any question on this product at the telephone number or address listed in this manual. Keep this manual available for reference whenever this product is being handled or used. Provide this manual to any new owners and/or operators. This manual covers model(s):

- 20" HIGH SNOW BLADES - 54"-78" WIDE (20-35HP)
- 24" HIGH SNOW BLADES - 60"-96" WIDE (30-50HP)
- 30" HIGH SNOW BLADES - 72"-108" WIDE (30-80HP)
- 34" HIGH SNOW BLADES - 108"-168" WIDE (60-125HP)
- 42" HIGH SNOW BLADES - 144"-192" WIDE (90-200HP)

GENERAL INFORMATION

The purpose of this manual is to assist in assembling, mounting, operating, and maintaining your Snow Blade. Read this manual carefully to obtain valuable information and instructions that will help you achieve years of safe and dependable service. The illustrations and data used in this manual were current at the time of printing, but due to possible engineering and/or production changes, this product may vary slightly in detail. Martatch Attachments reserves the right to redesign and/or change components as may be necessary without notification to anyone.

Throughout this manual, references may be made to:

Power source - The engine-driven machine to which this product is attached.

Right, Left Front, Rear - Directions are determined in relation to the operator of the equipment when seated in the normal operation position.

Important - Precautions that must be followed to prevent substandard performance.

Owner and Operator Safety Information

THINK SAFE BE SAFE !



This symbol by itself or with a warning word throughout this manual is used to call your attention to instructions involving your personal safety or the safety of others. Failure to follow these instructions can result in injury or death.



DANGER - This signal word is used where serious injury or death will result if the instructions are not followed properly.



WARNING - This signal word is used where serious injury or death could result if the instructions are not followed properly.



CAUTION - This signal word is used where minor injury could result if the instructions are not followed properly.



NOTICE - Notice indicates a property damage message

SAFETY PRECAUTIONS



WARNING! Read Manual Prior to Installation

Improper installation, operation, or maintenance of this equipment could result in serious injury or death. Operators and maintenance personnel should read this manual, as well as all manuals related to the Power Source before beginning installation, operation, or maintenance.



WARNING! Read and Understand All Safety Statements

Read all safety decals and safety statements in all manuals prior to operating or working on this equipment. Know and obey all O.S.H.A. regulations, local laws, and other professional guidelines for your operation. Know and follow safe work practices when assembling, maintaining, repairing, mounting, removing, or operating this product.



WARNING! Know Your Equipment

Know your equipment's capabilities, controls and operations before operating. Visually inspect your equipment before you start, and never operate equipment that is not in proper working order with all safety devices intact. Check all hardware to ensure it is tight. Make certain that all locking pins, latches, and connection devices are properly installed and secured. Remove and replace any damaged, fatigued, or excessively worn parts. Make certain all safety decals are in place and are legible. Keep decals clean, and replace them if they are hard to read.

SAFETY PRECAUTIONS



WARNING! Protect Against Flying Debris

Always wear proper safety glasses, goggles or a face shield when driving pins in or out, or when any operation causes dust, flying debris, or any other hazardous material.



WARNING! Lower or Support Raised Equipment

Lower attachment to the ground before leaving operator's station. Do not work under raised booms without taking the proper action to support them, or lower booms to ground level.



WARNING! Use Care When Working With Hydraulic Fluid Pressure

Hydraulic fluid under pressure can penetrate the skin and cause serious injury or death. Hydraulic leaks under pressure may not be visible. Before connecting or disconnecting hydraulic hoses, read your Power Source operator's manual for detailed instructions on connecting and disconnecting hydraulic hoses or fittings.

- Keep unprotected body parts, such as face, eyes, and arms as far away as possible from a suspected leak. Flesh injected with hydraulic fluid may develop gangrene or other permanent disabilities.
- If injured by fluid, see a doctor at once.
- Wear safety glasses, protective clothing when searching for hydraulic leaks. **DO NOT USE YOUR HANDS!**



WARNING! DO NOT MODIFY MACHINE OR ATTACHMENTS

Modifications may weaken the integrity of the attachment and may impair the function, safety, life, and performance of the attachment. When making repairs, use only the manufacturer's genuine parts, following authorized instructions. Other parts may be substandard in fit and quality. Contact Martatch Attachments before modifications are made.



WARNING! SAFELY MAINTAIN AND REPAIR EQUIPMENT

- Do not wear loose clothing, or any accessories that can catch in moving parts. If you have long hair, cover or secure it so that it does not become entangled in the equipment.
- Work on a level surface in a well-lit area.
- Use the correct tool for the job at hand. Make sure they are in good condition for the task required.
- Wear the protective equipment specified by the tool manufacturer. (i.e. safety glasses, work gloves, protective shoes, hardhat etc.).



WARNING! SAFELY OPERATE EQUIPMENT

Do not operate equipment until you are completely trained by a qualified operator in how to use the controls, know its capabilities, and all safety requirements. See Power Source manual for these instructions.

- Keep all step plates, grab bars, pedals, controls, etc. free of dirt, grease, debris, and oil.
- Never allow anyone to be around the equipment when it is operating.
- Do not allow riders on the attachment or the Power Source.
- Do not operate the equipment from anywhere other than the correct operators position.
- Never leave equipment unattended with the engine running or with attachment in a raised position.
- Do not alter or remove any safety feature from the Power Source or this attachment.
- Know your work site safety rules as well as traffic rules and flow. When in doubt on any safety issue, contact your supervisor or safety coordinator for an explanation.

SAFETY SIGN AND LOCATION

The diagram on this page shows the location of the decals the decals are identified by their part numbers, with reductions of the actual decals located on the bottom of page. Use this information to order replacements for lost or damaged decals. Be sure to read all decals before operating the attachment. They contain information you need to know for both safety and product longevity.

INSTRUCTIONS

- Keep all safety signs clean and legible.
- Replace all missing or damaged safety signs.
- When replacement parts with safety signs attached, new parts must also have safety signs attached.
- Safety signs are available from Martatch Attachments.

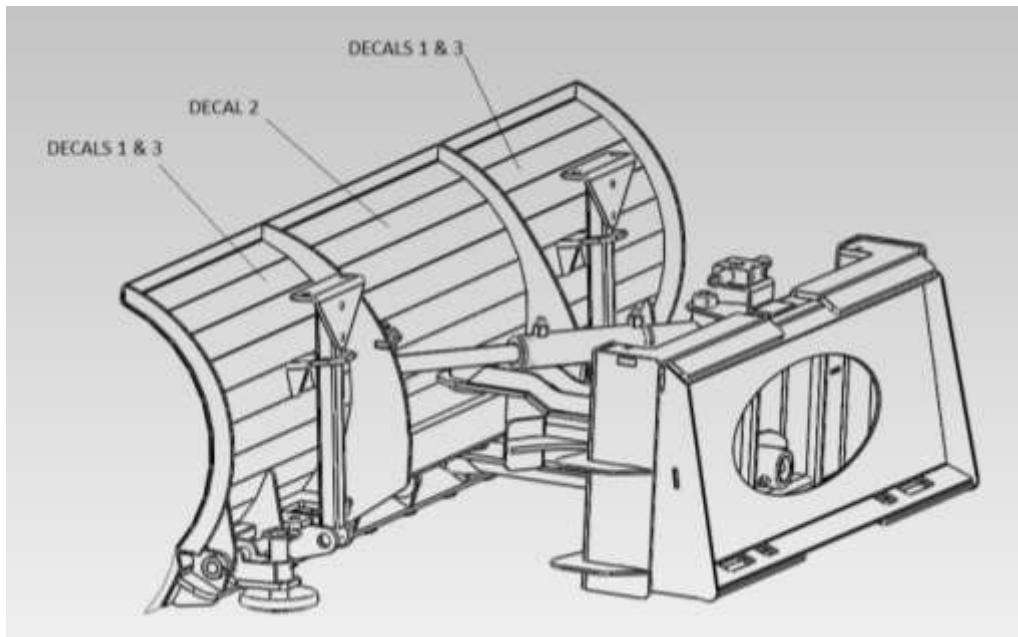

#1 WARNING- HIGH PRESSURE FLUID

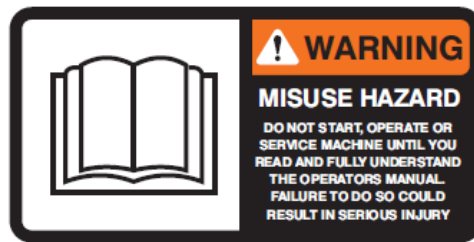

#2 WARNING- READ MANUAL



#3 WARNING- CRUSH HAZARD

POWER SOURCE SPECIFICATIONS



IMPORTANT Exceeding any of the maximum recommended power source specifications can result in damage to this product and void all warranties.

Recommended Horse Power on Power Source for model(s),

- 20" High Snow Blade is 20-35 hp
- 24" High Snow Blade is 30-50 hp
- 30" High Snow Blade is 30-80 hp
- 34" High Snow Blade is 60-125 hp
- 42" High Snow Blade is 90-200 hp

Maximum Hydraulic Pressure 4,000 psi

To maintain required Power Source stability add Rear Counterweights, Note see Power Source manuals for correct weight needed. DO NOT EXCEED MAXIMUM WEIGHT LIMIT.

SNOW BLADE SPECIFICATIONS

20" High Snow Blade (20-35 hp)					
MODEL	OVERALL WIDTH	OVERALL HEIGHT	CUTTING EDGE WIDTH		SHIPPING WEIGHT
			STRAIGH	ANGLED	
MSB54X20	54"	20"	54"	46-3/4"	450 lbs.
MSB60X20	60"	20"	60"	52"	465 lbs.
MSB66X20	66"	20"	66"	57-1/8"	480 lbs.
MSB72X20	72"	20"	72"	62-3/8"	495 lbs.
MSB78X20	78"	20"	78"	67-5/8"	510 lbs.

24" High Snow Blade (30-50 hp)					
MODEL	OVERALL WIDTH	OVERALL HEIGHT	CUTTING EDGE WIDTH		SHIPPING WEIGHT
			STRAIGH	ANGLED	
MSB60X24	60"	24"	60"	52"	610 lbs.
MSB72X24	72"	24"	72"	62-3/8"	640 lbs.
MSB78X24	78"	24"	78"	67-5/8"	650 lbs.
MSB84X24	84"	24"	84"	72-3/4"	690 lbs.
MSB90X24	90"	24"	90"	78"	708 lbs.
MSB96X24	96"	24"	96"	83-1/8"	743 lbs.

SNOW BLADE SPECIFICATIONS

30" High Snow Blade (30-80 hp)					
MODEL	OVERALL WIDTH	OVERALL HEIGHT	CUTTING EDGE WIDTH		SHIPPING WEIGHT
			STRAIGH	ANGLED	
MSB72X30	72"	30"	72"	62-3/8"	840 lbs.
MSB84X30	84"	30"	84"	72-3/4"	990 lbs.
MSB96X20	96"	30"	96"	83-1/8	1040 lbs.
MSB108X20	108"	30"	108"	93-5/8"	1090 lbs.

34" High Snow Blade (60-125 hp)					
MODEL	OVERALL WIDTH	OVERALL HEIGHT	CUTTING EDGE WIDTH		SHIPPING WEIGHT
			STRAIGH	ANGLED	
MSB108X34	108"	34"	108"	93-5/8"	1615 lbs.
MSB120X34	120"	34"	120"	104"	1675 lbs.
MSB144X34	144"	34"	144"	124-3/4"	1945 lbs.
MSB168X34	168"	34"	168"	145-1/2"	2075 lbs.

42" High Snow Blade (90-200 hp)					
MODEL	OVERALL WIDTH	OVERALL HEIGHT	CUTTING EDGE WIDTH		SHIPPING WEIGHT
			STRAIGHT	ANGLED	
MSB144X42	144"	42"	144"	124-3/4"	2450 lbs.
MSB168X42	168"	42"	168"	145-1/2"	2765 lbs.
MSB192X42	192"	42"	192"	166-3/8"	3005 lbs.

- Spring Trip Cutting Edge
- Lateral Float
- Hydraulic Angle 30 degrees both ways
- Reversible Cutting Edge
- Adjustable Skid Shoes
- Hydraulic Crossover Relief Valve

BOLT TORQUE SPECIFICATIONS

Diameter (Inches)	Wrench Size	MARKING ON BOLT HEAD					
		SAE 2		SAE 5		SAE 8	
		lbs-ft	N-m	lbs-ft	N-m	lbs-ft	N-m
1/4"	7/16"	6	8	10	13	14	18
5/16"	1/2"	12	17	19	26	27	37
3/8"	9/16"	23	31	35	47	49	67
7/16"	5/8"	36	48	55	75	78	106
1/2"	3/4"	55	75	85	115	120	163
9/16"	13/16"	78	106	121	164	171	232
5/8"	15/16"	110	149	170	230	240	325
3/4"	1-1/8"	192	261	297	403	420	569
7/8"	1-5/16"	306	416	474	642	669	907
1"	1-1/2"	467	634	722	979	1020	1383

Diameter & Thread Pitch (Inches)	Wrench Size	FINE THREAD			
		MARKING ON HEAD			
		Metric 8.8		Metric 10.9	
		N-m	lbs-ft	N-m	lbs-ft
6 x 1.00	10 mm	8	9	11	8
8 x 1.00	13 mm	21	16	29	22
10 x 1.25	16 mm	41	30	57	42
12 x 1.25	18 mm	75	55	103	76
14 x 1.50	21 mm	118	87	163	120
16 x 1.50	24 mm	181	133	250	184
18 x 1.50	27 mm	263	194	363	268
20 x 1.50	30 mm	367	270	507	374
22 x 1.50	34 mm	495	365	684	505
24 x 2.00	36 mm	623	459	861	635
30 x 2.00	46 mm	1258	928	1740	1285

BOLT TORQUE SPECIFICATIONS

Diameter & Thread Pitch (Inches)	Wrench Size	COARSE THREAD MARKING ON HEAD			
		Metric 8.8		Metric 10.9	
		N-m	lbs-ft	N-m	lbs-ft
		6 x 1.00	10 mm	8	9
8 x 1.25	13 mm	20	15	27	20
10 x 1.50	16 mm	39	29	54	40
12 x 1.75	18 mm	68	50	94	70
14 x 2.00	21 mm	109	80	151	111
16 x 2.00	24 mm	169	125	234	173
18 x 2.50	27 mm	234	172	323	239
20 x 2.50	30 mm	330	244	457	337
22 x 2.50	34 mm	451	332	623	460
24 x 3.00	36 mm	571	421	790	583
30 x 3.00	46 mm	1175	867	162	1199

SNOW BLADE MOUNTING



WARNING! READ MANUAL PRIOR TO INSTALLATION

Improper installation, operation, or maintenance of this equipment could result in serious injury or death. Operators and maintenance personnel should read this manual, as well as all manuals related to this equipment and the Power Source thoroughly before beginning installation, operation, or maintenance. FOLLOW ALL SAFETY INSTRUCTIONS IN THIS MANUAL AND THE POWER SOURCE MANUAL(S).

1. Inspect the attachment for shipping damage. If damage does exist, do not operate until the damaged parts have been replaced or repaired.
2. Place this product on a firm, level surface that is large enough to safely accommodate this product, your prime mover and all workers involved in the mounting process.
3. Refer to the Power Source operator's manual(s) for your, loader, and quick-attach and follow the mounting instructions contained therein.
4. When shipped the hydraulic cylinder(s) on this product may contained air, or an air-fluid mixture. Failure to remove all the air from the hydraulic cylinder(s) can cause uneven, jerky cylinder movement when the hydraulic controls are being operated and unwanted cylinder movement when the controls are not being operated.

See Maintenance section for annual maintenance.

Setup



READ AND UNDERSTAND ALL SAFETY STATEMENTS

Read all safety decals and safety statements in all manuals before beginning any setup. Know and obey all O.S.H.A. regulations, local laws, and other professional guidelines for your operation. Know and follow good work practices when assembling, maintaining, repairing, mounting, removing, or operating this equipment.

Spring tension is set from factory. If cutting edge trips too easily, simply tighten the eye bolts above the springs to length springs.

SNOW BLADE OPERATION



READ AND UNDERSTAND ALL SAFETY STATEMENTS

Read all safety decals and safety statements in all manuals before beginning any setup. Know and obey all O.S.H.A. regulations, local laws, and other professional guidelines for your operation. Know and follow good work practices when assembling, maintaining, repairing, mounting, removing, or operating this equipment.



WARNING! Failure to obey the following procedures could result in death or serious injury.

- Never operate this product where visibility is obstructed the operated view.
- Always operate at a safe operating speed for the surrounding conditions.



IMPORTANT

Striking objects hidden in snow or pushing materials other than snow can result in damage to this product and may void warranties.

Before any snowfall, locate any obstructions (i.e. curbs, sidewalks, gas meters, shrubs, fences, etc.) and any variations in elevation (i.e. retaining walls, slopes, sewer man holes, etc.) so that these elements can be avoided during snow removal operation.

SNOW BLADE MAINTENANCE



READ AND UNDERSTAND ALL SAFETY STATEMENTS

Read all safety decals and safety statements in all manuals before beginning any setup. Know and obey all O.S.H.A. regulations, local laws, and other professional guidelines for your operation. Know and follow good work practices when assembling, maintaining, repairing, mounting, removing, or operating this equipment.

BEFORE EACH USE

- Make sure that all other fasteners are in place and are performing their specified function.
 - Make sure that all hydraulic fittings are tightened and that there are no leaks in any fittings or hoses.
 - Make sure that all safety signs are in place, are clean, and are legible. (See the safety sign and location)
 - Check all wear parts, replace any damaged or excessively worn parts.
- Bolt on cutting edge is reversible by flipping top to bottom and reinstalling for more wear.

AFTER EVERY 10 HOURS OF USE

- Grease all grease fittings as marked on blade.

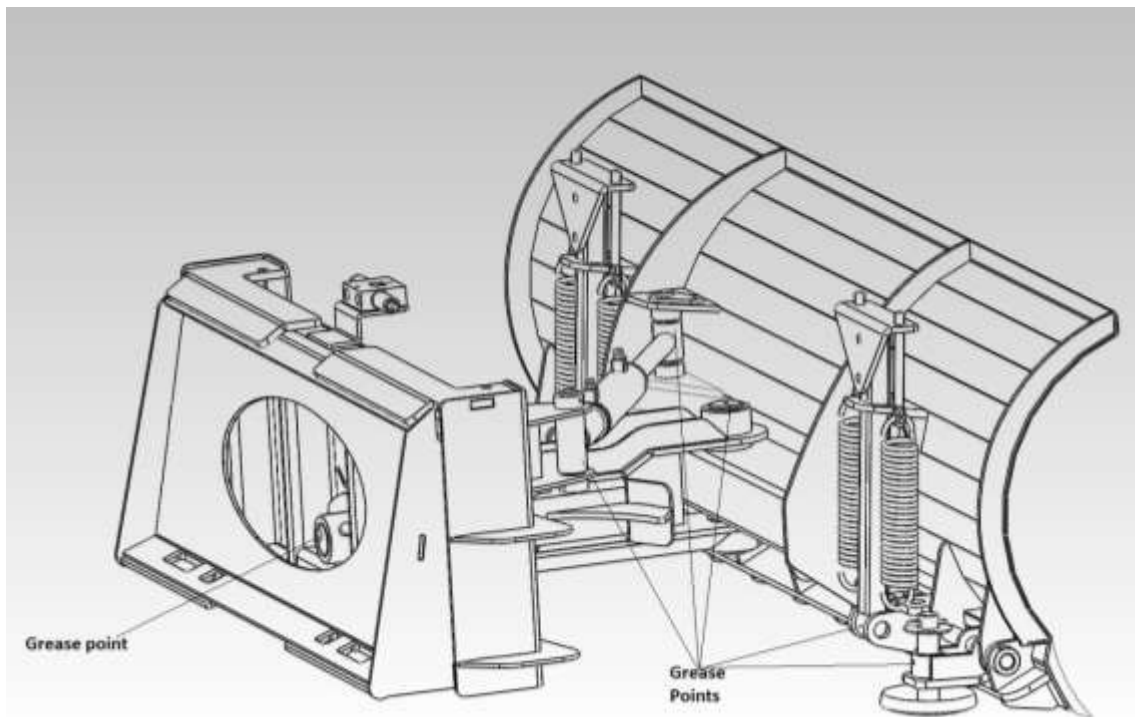

SNOW BLADE ILLUSTRATION

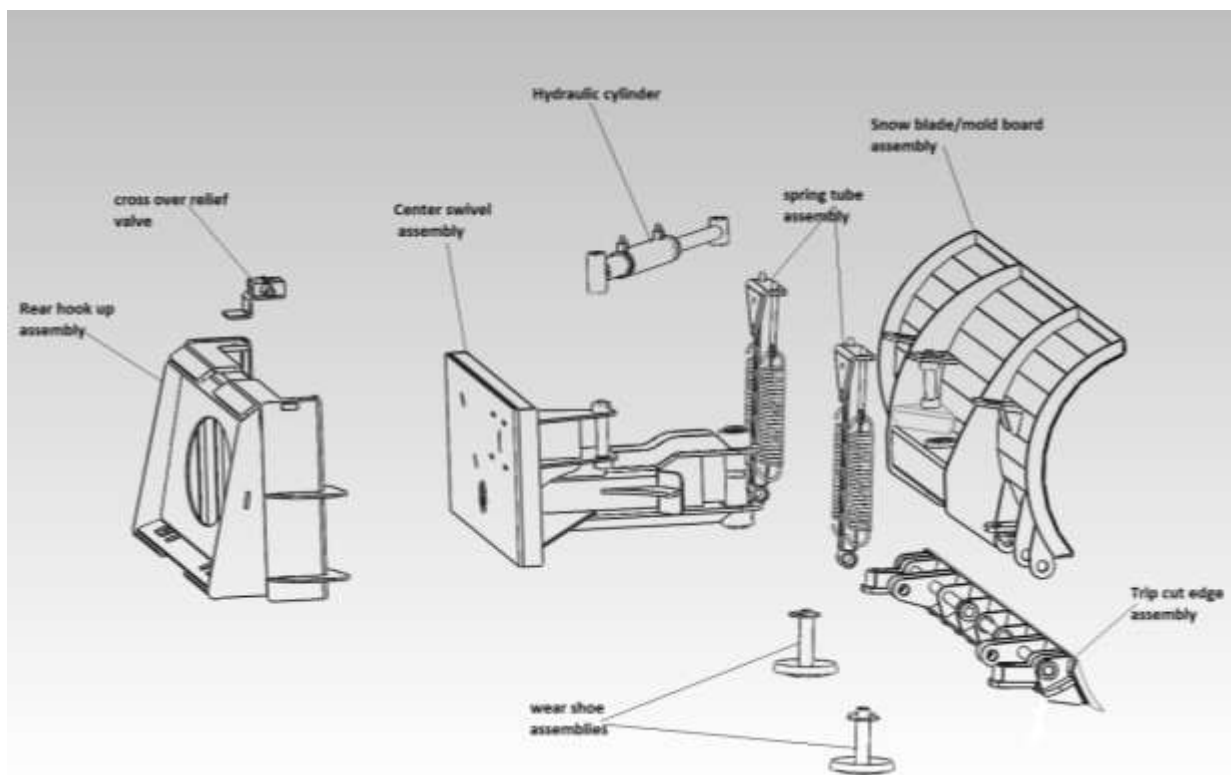

TROUBLE SHOOTING

PROBLEM	POSSIBLE CAUSE	SOLUTION
Hydraulic Malfunction	Low fluid level	Check hydraulic fluid
	Improper hose hook-up	Check and correct line connection
	Broken or damage hydraulic line	Replace damaged line
	Cylinder leaking	Replace cylinder seals
	Dirty fluid or filter	Replace filter and fluid
	Fluid heating	Use recommended fluid for conditions
		Check for restricted fluid flow
Cold hydraulic fluid	Allow fluid to warm up to operated temperature	
Cutting Edge Digging into to surface	Blade tipped forward or soft surface	Tip blade back to ride on skid shoes
Cutting Edge Wear Prematurely	Blade tip tipped forward	Tip blade back to ride on skid shoes
	Blade tip tipped forward	Adjust skid shoes to proper height
	Down pressure on blade	Run in "Float" position
Cutting Edge Trips too Easily	Tension too loose on trip springs	Tighten trip spring tension

Martatch Attachments Warranty Policy

All equipment sold by MARTATCH ATTACHMENTS is warranted to be free from defects of material and workmanship. The company will not be liable for indirect or consequential damages. The company's liability will be limited exclusively to replacing or repairing without charge, at its factory or elsewhere, at its discretion. Any material or workmanship defects that becomes apparent within one year from the date which the equipment was purchased. The buyer by the acceptance of the equipment will assume all liability for any damages that may result from the use or misuse by his employees or others.

All claims must be reported to a MARTATCH ATTACHMENTS representative prior to any repairs or modification.

All claims are subject to a MARTATCH ATTACHMENTS representative approval.

All claims must be accompanied by pictures of the faulty product.

MARTATCH ATTACHMENTS Warranty will not cover product that has been misused or modification in an unauthorized manner.

MARTATCH ATTACHMENTS Warranty will not cover normal wear on Attachments.



MARTATCH ATTACHMENTS

4350 HESSEN STRASSE
R.R. #3
WELLESLEY, ON N0B 2T0
Canada
Phone: 1-800-698-5510
Email: sales@martatch.com
Website: www.martatch.com

